

Temperature Sensor 4050

D360 - March 2006

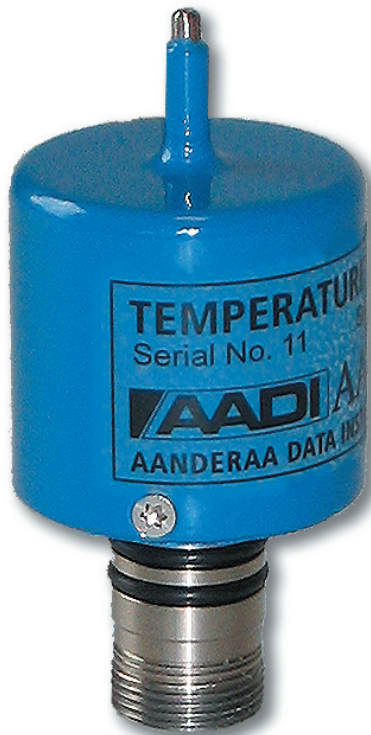

Temperature Sensor 4050 is a compact fully integrated sensor for measuring the water temperature. The sensor is designed to be mounted on Aanderaa Recording Current Meters, RCM 9 series and RCM 11. The sensor can also be used as stand alone, and is easily integrated in other measurement systems with third party dataloggers.

Temperature Sensor 4050 advantages:

- **Smart Sensor technology**
- **Configurable range for improved accuracy when used with Aanderaa current meters**
- **Depth rating of 6000 meters**
- **Short response time, less than 2 seconds**
- **Rugged and Robust with minimal and simple maintenance needs**
- **Resolution: 0.001°C**
- **Accuracy: $\pm 0.03^\circ\text{C}$**
- **Output format: Aanderaa SR10, RS232**

The Temperature Sensor 4050 is an intelligent sensor designed to be used on Aanderaa Dataloggers as well as in other measurement systems. The sensor is based on a thermistor-bridge. A Digital Signal Processor controls the sampling of the bridge and calculates the calibrated temperature in engineering units. The sensor is housed in a rugged titanium cylinder.

The processed data is available as either RS232 or Aanderaa SR10 output. The user may configure the measurement range on the SR10 output; best accuracy is achieved with a short measurement range.

The sensor can be mounted directly on the top end plate of the Aanderaa RCM 9 or RCM 11 and connected to the Main Control Board (Electronic Board) with a short cable, Sensor

Cable 3854. The sensor can also be connected to the top end plate via a cable/string for temperature measurements in a different site than the instrument.

The 10-pin receptacle in the sensor foot mates with Aanderaa Plug 3216A giving access to RS-232 output. For connection to a Personal computer (PC) the 1.5-meter (4.921ft) Sensor Cable 3855 can be used. It is furnished with a watertight 10-pin plug at the sensor end. An additional USB plug is used for providing power to the sensor.

The distance from the PC can be extended to 15 meters by using a Cable Coupler 3472 and a standard Connecting Cable 3282 with watertight titanium plugs.

AADI AANDERAA

AANDERAA DATA INSTRUMENTS • www.aadi.no

Reliable Solutions 1

Specifications

D360 - March 2006

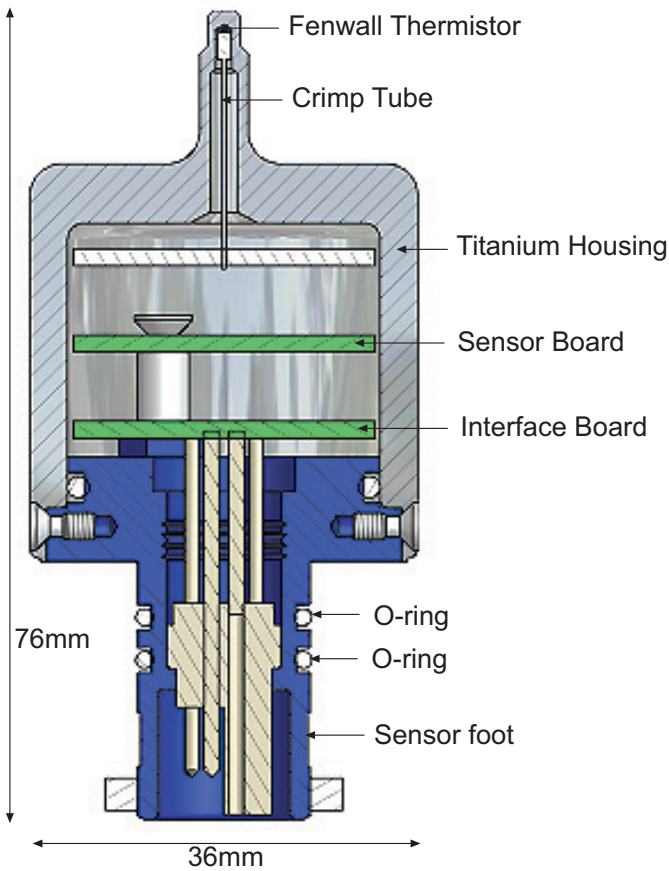

Temperature:

- Range, Model A:* 0 to 36°C (32 – 96.8°F)(1)
- Range, Model B:* -4 to 36°C (24.8 – 96.8°F)(1)
- Resolution:* 0.001°C (0.0018°F)(2)
- Accuracy:* ±0.03°C (0.054°F)
- Response Time (63%):* <2 seconds

Output format:

Aanderaa SR10, ASCII RS-232(3)

Sampling Interval:

2s – 255 minutes
(SR10 Controlled by Datalogger)

Supply voltage:

6 to 14VDC (SR10 -6 to -14VDC)

Current drain(@ 9V):

- Average:*
 - RS-232: 14mA/S + 0.25mA where S is sampling interval in seconds
 - SR10: 3 mA/T where T is recording interval in minutes
- Maximum:* 50 mA
- Quiescent:* 0.25 mA (SR10, 0mA)

Operating temp.:

-5 to +40°C (23 – 104°F)

Electrical connection:

10-pin receptacle mating plug
3216A

Dimensions (DxH):

O.D.36 x 76mm (O.D1.4”x3”)

Weight:

120g (4.23oz)

Materials:

Titanium and Epoxy coating

Warranty:

Two years against faulty materials and workmanship

Accessories:

- included:* Sensor Cable 3854
- not included:* Sensor Cable 3855 to PC

- (1) Extended range available on request. The range on the SR10 output is user-configurable
- (2) for SR10, 0.1% of configured range or 0.01°C (0.018°F), whichever is greater
- (3) 9600 baud, 8 data bits, 1 stop bit, No parity, Xon/Xoff Handshake

The above specifications are for the stand-alone sensor only, not the installation it is utilized with.

Specifications subject to change without prior notice.

PIN CONFIGURATION

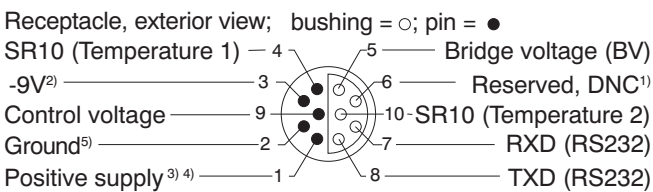

- ¹⁾ DNC: Do Not Connect
- ²⁾ Supply for SR10 Operation
- ³⁾ Ground for SR10 Operation
- ⁴⁾ Supply for RS-232 Operation
- ⁵⁾ Ground for RS-232 Operation

5851 BERGEN, NORWAY
TEL. +47 55 60 48 00
FAX. +47 55 60 48 01

http://www.aadi.no
e-mail: info@aadi.no

Representative's Stamp

